

Алматы (727)345-47-04
Ангарск (3955)60-70-56
Архангельск (8182)63-90-72
Астрахань (8512)99-46-04
Барнаул (3852)73-04-60
Белгород (4722)40-23-64
Благовещенск (4162)22-76-07
Брянск (4832)59-03-52
Владивосток (423)249-28-31
Владикавказ (8672)28-90-48
Владимир (4922)49-43-18
Волгоград (844)278-03-48
Вологда (8172)26-41-59
Воронеж (473)204-51-73
Екатеринбург (343)384-55-89

Иваново (4932)77-34-06
Ижевск (3412)26-03-58
Иркутск (395)279-98-46
Казань (843)206-01-48
Калининград (4012)72-03-81
Калуга (4842)92-23-67
Кемерово (3842)65-04-62
Киров (8332)68-02-04
Коломна (4966)23-41-49
Кострома (4942)77-07-48
Краснодар (861)203-40-90
Красноярск (391)204-63-61
Курск (4712)77-13-04
Курган (3522)50-90-47
Липецк (4742)52-20-81

Магнитогорск (3519)55-03-13
Москва (495)268-04-70
Мурманск (8152)59-64-93
Набережные Челны (8552)20-53-41
Нижний Новгород (831)429-08-12
Новокузнецк (3843)20-46-81
Ноябрьск (3496)41-32-12
Новосибирск (383)227-86-73
Омск (3812)21-46-40
Орел (4862)44-53-42
Оренбург (3532)37-68-04
Пенза (8412)22-31-16
Петрозаводск (8142)55-98-37
Псков (8112)59-10-37
Пермь (342)205-81-47

Ростов-на-Дону (863)308-18-15
Рязань (4912)46-61-64
Самара (846)206-03-16
Санкт-Петербург (812)309-46-40
Саранск (8342)22-96-24
Саратов (845)249-38-78
Севастополь (8692)22-31-93
Симферополь (3652)67-13-56
Смоленск (4812)29-41-54
Сочи (862)225-72-31
Ставрополь (8652)20-65-13
Сургут (3462)77-98-35
Сыктывкар (8212)25-95-17
Тамбов (4752)50-40-97
Тверь (4822)63-31-35

Тольятти (8482)63-91-07
Томск (3822)98-41-53
Тула (4872)33-79-87
Тюмень (3452)66-21-18
Улан-Удэ (3012)59-97-51
Ульяновск (8422)24-23-59
Уфа (347)229-48-12
Хабаровск (4212)92-98-04
Чебоксары (8352)28-53-07
Челябинск (351)202-03-61
Череповец (8202)49-02-64
Чита (3022)38-34-83
Якутск (4112)23-90-97
Ярославль (4852)69-52-93

Россия +7(495)268-04-70

Казахстан +7(727)345-47-04

Беларусь +(375)257-127-884

Узбекистан +998(71)205-18-59

Киргизия +996(312)96-26-47

<https://raypa.nt-rt.ru> || rpa@nt-rt.ru

Vertical autoclaves without drying

AES Series **CLASSIC LINE**



Why choose RAYPA?

Expert manufacturer, original design,
global brand



GLOBAL REACH

With half a century of experience, we have a long list of satisfied customers around the world. Currently, we export 85% of our annual turnover and have a stable network of distributors with presence in over 100 countries.



EFFICIENT TECHNICAL SERVICE

Our team of highly qualified technicians and engineers is expert in our products. If you experience a technical issue, it will be our priority to rectify it. When you purchase a RAYPA unit, you're guaranteed top-level support and technical assistance.



EXPERT MANUFACTURER

After more than 45 years in the industry, RAYPA is a global leader in the manufacture of laboratory autoclaves. Each of our autoclaves is designed and manufactured entirely within our modern facility equipped with the latest technology.



FULL AND CUSTOMIZABLE RANGE

We offer an extensive portfolio of laboratory autoclaves to cover multiple applications and market segments. Discover the combination of autoclave model and accessories that best fits your needs within our 11 series and 35 available models.



INNOVATION AND QUALITY

Our products feature advanced technology, ongoing innovation, superior construction quality, and are designed for a long service life. Our technical and engineering staff works tirelessly every day to optimize our products and exceed our customers' expectations.



COMPREHENSIVE CONSULTANCY

Our team of specialists assesses each project and provides guidance to clients on the option that best suits their requirements. After the sale, we offer training on the use and recommended maintenance of each unit to ensure its optimal operation and extend its lifespan.

Vertical autoclaves without drying

AES Series vertical floor-standing autoclaves with top-loading access are designed to meet the essential needs of general labware sterilization across various educational institutions and research facilities, all while boosting laboratory productivity. With a spacious chamber and optimized use of resources like water, energy, and time, these autoclaves provide an efficient and cost-effective solution to handle laboratory workloads effectively.

RECOMMENDED APPLICATIONS

-  Culture media and liquids
-  Glassware
-  Plastics and metal objects
-  Laboratory waste bags*

*For this application, the sterilization time must be extended, the chamber should not be fully loaded, and chemical and/or biological tests should be used to validate the proper sterilization of the load.



AES Series

MAIN FEATURES

ECONOMIC AND DURABLE

AES Series autoclaves are economic, robust and offer excellent performance for general laboratory sterilization procedures. They can be used either for solids and liquids sterilization procedures and they consume limited valuable laboratory resources such as water, power or operator time.

MULTIPLE TYPES OF STERILIZATION CYCLES

Multiple options available to perform solids or liquids sterilization. Optional core probe for liquid sterilization, temperature holding at the end of the sterilization cycle for culture media, and manual unsteaming push-button for a faster cooling phase of solids

EFFORTLESS INSTALLATION AND MAINTENANCE

Designed for simplicity, AES Series autoclaves are plug and play, requiring only an electrical connection. They can operate without a dedicated drain and feature casters for seamless mobility across your laboratory space, making them as versatile as they are easy to use.

SAFETY FIRST

AES Series autoclaves are designed with several features to ensure the safety of the operators. These include an overpressure safety valve, a thermally insulated door, an overtemperature safety thermostat, an open door detection system and an independent safety pneumatic system that locks the main door while positive pressure is present in the sterilization chamber.

ADVANTAGES



The sterilization chamber and door are made of high-quality AISI-316L stainless steel, providing exceptional resistance to corrosion.



Available special models with increased heating capacity to achieve faster heating and sterilization phases.



Autoclaves manufactured in full compliance with all applicable European Union quality, regulatory and safety standards.



Adjustable temperature holding at the end of the sterilization cycle between 40-80°C (agar mode).



Steam generation by powerful Incoloy® 825 electric heating elements assembled inside the sterilization chamber and shielded by a protective grid.



Programmable auto-start for up to 24h.



Control by a PID microprocessor with 4 predefined and 6 editable programs, adjustable by time, temperature and type of sterilization cycle (agar mode and/or flexible temperature probe control).



Optional software for sterilization data management.



Manual steam release push-button for a faster cooling phase in solids sterilization cycles.



Plug and play equipment, no plumbing required.



Seamless mobility, all models include casters.



Optional embedded or external printer.

WORKING PRINCIPLE

AES Series autoclaves provide a solution for the multiple sterilization needs of a general laboratory, including liquids, culture media, biological waste, contaminated media, instruments, glassware and other laboratory items.

The load has to be placed in baskets inside the chamber, and after manually filling the tank with purified water, the equipment starts to heat up and purge until the set combination of sterilization time and sterilization temperature is reached.



Quick steam release push-button

PID microprocessor



2 position drain tap



Sterilization chamber made of AISI-316L stainless steel



Powerful heating elements to generate steam



Optional medical-grade casters with brakes*



*Standard casters included. Optional: medical-grade casters with brakes (Ref. 4WHBR).

OPERATION OF A STERILIZATION CYCLE

HEATING PHASE

- In this initial step, the powerful heating elements assembled at the bottom of the sterilization chamber heat up dramatically, transferring energy to water to produce saturated steam throughout the chamber.
- To shorten the duration of this step, RAYPA offers special models with increased heating capacity, a feature of particular interest for autoclaves operating in laboratories with high workloads.

STERILIZATION PHASE

- Upon reaching the set sterilization temperature inside the chamber, the sterilization phase begins accurately sustaining the temperature throughout the duration of this phase.
- This crucial step is controlled by a PT-100 Class A temperature probe located within the chamber. As an option for liquids sterilization processes, this phase can be regulated by a flexible PT-100 Class A temperature probe located inside a sample.

COOLING PHASE

- At the end of the sterilization phase, a natural cooling phase begins. A beep will sound when a safe temperature is reached allowing the chamber to be opened.
- In solid programs, discharge can be manually forced through a push-button to reduce the duration of the cooling phase.
- In programs with agar mode, the preprogrammed temperature (selectable between 40°C and 80°C) will be maintained indefinitely.

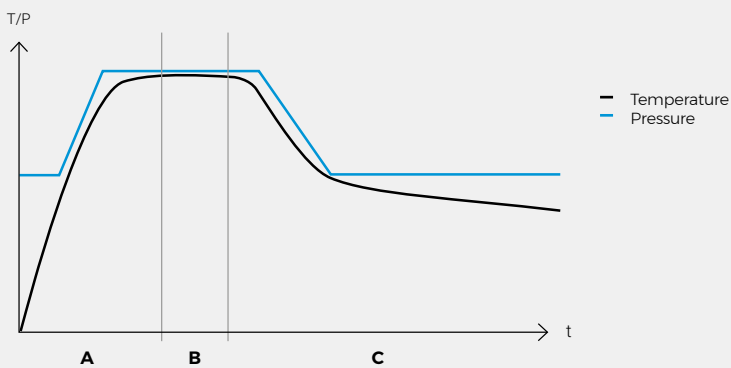

A. Heating phase



B. Sterilization phase

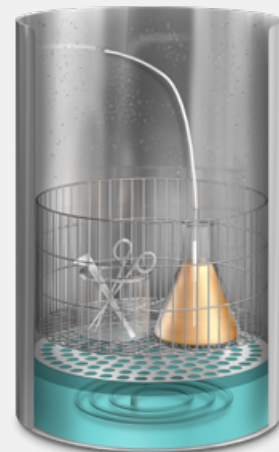

C. Cooling phase

PREDEFINED PROGRAMS

Program N°	Sterilization temperature °C	Sterilization time min	Program mode
P0	115	60	SOL/LIQ-1
P1	121	30	SOL/LIQ-1
P2	133	20	SOL/LIQ-1
P3	121	20	SOL/LIQ-1

AES Series autoclaves have a total of 10 programs, from P0 to P9, and the first four are predefined and protected.

The remaining programs, from P4 to P9, can be edited by setting the following parameters:

- Sterilization temperature.
- Sterilization time.
- Temperature control of the sterilization cycle can be performed by the chamber temperature probe or by the combined use of the chamber probe and the core probe.
- Sterilization with temperature maintenance at the end of the cycle (agar mode).

FUNCTIONS OF THE DISPLAY

The alphanumeric screen apart from showing the standard sterilization parameters also shows current sterilization phase and several visual alerts, including warning or failure messages. The available languages include English, Spanish, French and Catalan. To install other languages, please contact us.

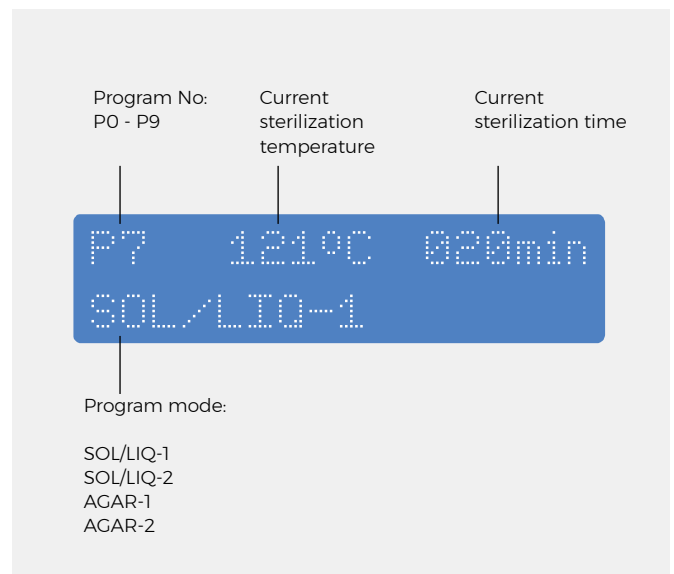

DIGITAL MICROPROCESSOR

Digital PID microprocessor with 6 push-buttons for simple programming and parameter selection.



LOADING CAPACITIES



ISO ERLLENMEYER FLASKS

Autoclave model	Usable volume L	250mL (Ø85 x 143mm)				500mL (Ø105 x 183mm)				1000mL (Ø131 x 230mm)				2000mL (Ø166 x 280mm)			
		Total baskets	Units / basket	Total units		Total baskets	Units / basket	Total units		Total baskets	Units / basket	Total units		Total baskets	Units / basket	Total units	
				A	B			A	B			A	B			A	B
AES-28	31	2	7	14	=	1	4	4	8	1	1	1	=	1	1	1	=
AES-50	50	3	7	21	28	1	4	4	12	1	1	1	3	1	1	1	2
AES-75	75	3	12	36	48	2	8	16	24	2	5	10	=	1	3	3	6
AES-110	110	4	12	48	60	3	8	24	32	3	5	15	=	1	3	3	9
AES-150	153	4	21	84	105	4	14	56	=	3	8	24	=	1	5	5	=

A: Number of units using standard baskets.

B: Number of units using specially designed baskets for the specific combination of autoclave model and container.



ISO BOTTLES

Autoclave model	Usable volume L	250mL (Ø70 x 143mm)				500mL (Ø80 x 185mm)				1000mL (Ø101 x 230mm)				2000mL (Ø136 x 260mm)			
		Total baskets	Units / basket	Total units		Total baskets	Units / basket	Total units		Total baskets	Units / basket	Total units		Total baskets	Units / basket	Total units	
				A	B			A	B			A	B			A	B
AES-28	31	2	9	18	=	1	7	7	14	1	4	4	=	1	1	1	=
AES-50	50	3	9	27	36	1	7	7	21	1	4	4	12	1	1	1	2
AES-75	75	3	20	60	80	2	14	28	42	2	8	16	=	1	4	4	8
AES-110	110	4	20	80	100	3	14	42	56	3	8	24	=	1	4	4	12
AES-150	153	4	33	132	165	4	24	96	=	3	15	45	=	1	8	8	24

A: Number of units using standard baskets.

B: Number of units using specially designed baskets for the specific combination of autoclave model and container.

The data contained within these tables, regarding load capacities, serves as a non-binding guide to assist you in the selection of the most appropriate autoclave model.

ACCESSORIES

INTEGRATED BASKET LIFT SYSTEM

References	CLASSIC-LIFT	CLASSIC-LIFT-R	
Dimensions L x D x H mm	800 x 300 x 2100	800 x 300 x 2600	
Power W	480	480	
Voltage V	230	230	
Frequency Hz	50/60	50/60	
Weight Kg	40	45	
Maximum load Kg	30	40	
For autoclaves with the following chamber volumes	79 L	✓	-
	115 L	✓	✓
	175 L	-	✓

- Stainless steel electric lift system built into the side of the autoclave with swivel arm to help load and unload heavy items. Push-button operation with opening up to 200°.
- Motor with auto brake system in the event of obstacles or overload.
- Available in two models: the standard lift system and reinforced lift system.
- It can be factory fitted or retrofitted.



Download technical data sheet

MOBILE BASKET LIFT SYSTEM

Reference	MOB-LIFT
Dimensions L x D x H mm	420 x 800 x 2200
Power W	200
Voltage V	115 - 230
Frequency Hz	50/60
Weight Kg	85
Maximum load Kg	30

- Stainless steel electric lift system with casters to help load and unload heavy items up to 30Kg.
- Equipped with long-life battery for cordless use.
- Push-button operation.
- Motor with auto brake system in the event of obstacles or overload.
- Compatible with any autoclave model.



Download technical data sheet

ACCESSORIES

STAINLESS STEEL WIRE BASKETS FOR STERILIZING CLEAN LOADS OR HEAVY ITEMS

References		CV-28	CV-75-130	CV-75S	CV-75	CV-150-130	CV-150S	CV-150M
Dimensions	External Ø x H mm	270 x 185	370 x 130	370 x 180	370 x 265	470 x 130	470 x 190	470 x 235
	Internal Ø x H mm	260 x 180	360 x 125	360 x 175	360 x 260	460 x 125	460 x 185	460 x 230
Maximum capacity for autoclaves with the following chamber volumes	33 L	2	-	-	-	-	-	-
	55 L	3	-	-	-	-	-	-
	79 L	-	4	3	2	-	-	-
	115 L	-	6	4	3	-	-	-
	175 L	-	-	-	-	6	4	3



STAINLESS STEEL LIQUIDS COLLECTOR TRAY FOR WIRE BASKETS

References		TR-270	TR-370	TR-470
Dimensions	External Ø x H mm	240 x 50	320 x 50	420 x 50
	Internal Ø x H mm	238 x 48	318 x 48	418 x 48
For the following wire baskets models	CV-28	✓	-	-
	CV-75S & CV-75	-	✓	-
	CV-150S & CV-150M	-	-	✓



UNPERFORATED STAINLESS STEEL BASKETS FOR STERILIZING DIRTY LOADS OR OBJECTS WITH RISK OF SPILLAGE

References		CCI-28	CCI-75S	CCI-75	CCI-150S	CCI-150M
Dimensions	External Ø x H mm	270 x 185	370 x 180	370 x 265	470 x 190	470 x 235
	Internal Ø x H mm	260 x 180	360 x 175	360 x 260	460 x 185	460 x 230
Maximum capacity for autoclaves with the following chamber volumes	33 L	2	-	-	-	-
	55 L	3	-	-	-	-
	79 L	-	3	2	-	-
	115 L	-	4	3	-	-
	175 L	-	-	-	4	3



STAINLESS STEEL "SCHIMMELBUSCH" DRUM FOR STERILIZING INSTRUMENTS AND BIOHAZARDOUS LOADS

References		TBE-24x16	TBE-34x24	TBE-48x24
Dimensions	External Ø x H mm	240 x 165	340 x 240	480 x 240
	Internal Ø x H mm	230 x 155	330 x 230	470 x 230
Maximum capacity for autoclaves with the following chamber volumes	33 L	2	-	-
	55 L	4	-	-
	79 L	-	2	-
	115 L	-	3	-
	175 L	-	-	3



ACCESSORIES

STAINLESS STEEL CYLINDERS FOR STERILIZING PETRI DISHES

References		CEP-1027	CEP-1041	CEP-1427	CEP-1441
Dimensions	External Ø x H mm	100 x 270	100 x 410	140 x 270	140 x 410
Petri dishes	Maximum number dishes / cylinder	10	18	10	18
	Diameter Ø mm	80	80	120	120
Maximum capacity for autoclaves with the following chamber volumes	33 L	4	4	2	2
	55 L	8	4	4	2
	79 L	16	8	10	5
	115 L	24	16	15	10
	175 L	28	14	16	8

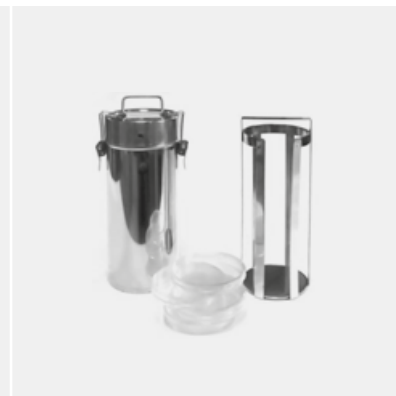

STAINLESS STEEL CYLINDERS FOR STERILIZING PIPETTES

References		CEPP-726	CEPP-740	CEPP-1025	CEPP-1435
Dimensions	External Ø x H mm	70 x 260	70 x 400	100 x 250	140 x 350
	Internal Ø x H mm	60 x 250	60 x 390	90 x 240	130 x 340
Maximum capacity for autoclaves with the following chamber volumes	33 L	11	11	6	6
	55 L	22	11	12	12
	79 L	42	21	20	10
	115 L	63	42	30	20
	175 L	90	30	51	34



STAINLESS STEEL WIRE BASKET WITH HEIGHT ADJUSTABLE TRAYS

References		SRA-R-300	SRA-R-400	SRA-R-500
External dimensions	Ø x H mm	250 x 190	350 x 180	450 x 180
Trays	References	TRAY-SRA-R-300	TRAY-SRA-R-400	TRAY-SRA-R-500
	Dimensions Ø x H mm	240 x 20	340 x 20	440 x 20
Maximum capacity for autoclaves with the following chamber volumes	33 L	2	-	-
	55 L	3	-	-
	79 L	-	3	-
	115 L	-	4	-
	175 L	-	-	4

*The purchase of a tray support comes with a set of two trays and six fastening clips. Likewise, the purchase of a tray includes a set of three fastening clips.

- For sterilization of instruments, small bags and other small objects that must be placed straight up.
- Material: AISI-304 stainless steel.

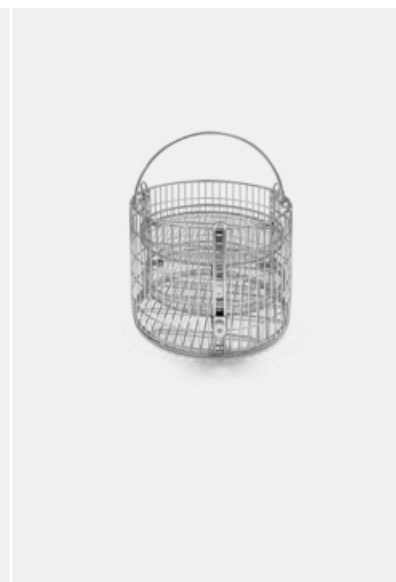



ACCESSORIES



FLEXIBLE TEMPERATURE PROBE PT-100 CLASS A

After installing this accessory, the temperature regulation of the sterilization cycle can either be controlled by the main chamber temperature probe or both the main chamber temperature probe and the flexible temperature probe.

The temperature control by the flexible temperature probe is especially advantageous for processes involving the sterilization of large volumes of liquids, where the sterilization process is regulated by both the temperature achieved in the center of the liquid sample as well as the temperature achieved in the sterilization chamber. Furthermore, should the autoclave be opened at chamber temperatures higher than 80°C there is a risk of liquids boiling over which can be avoided if the temperature of the sample is controlled throughout the sterilization procedure. Must be installed in our facilities.

Ref. PT-2

[Download technical data sheet](#)



EXTERNAL DOT MATRIX PRINTER

Prints program number, cycle number, temperature, pressure, date and hour and error messages.

Selectable print frequency between 10 and 240 seconds.

Connection: RS-232.

Ref. ITS

Consumables: PAPER-ITS for paper and 70945 for ribbon.

[Download technical data sheet](#)



EMBEDDED THERMAL PRINTER

Prints program number, cycle number, temperature, pressure, date and hour of the run and error messages.

Selectable print frequency between 10 and 240 seconds.

Must be installed at our factory.

Ref. IT

Consumable: PAPER-IT for paper

[Download technical data sheet](#)



SOFTWARE SW7000

Communication software between the equipment and the PC for display and recording in real time or display after each cycle. Cycles can also be printed or exported to Excel.

PC connection via RS-232.

It is supplied with an RS-232 cable, a USB memory stick including installation software and drivers, and an RS-232 to USB adapter.

Ref. SW7000

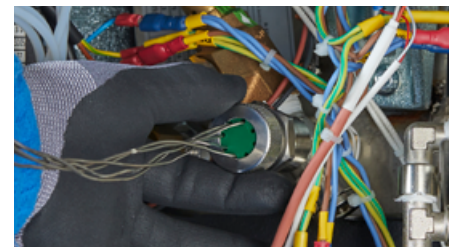

CABLE GLAND

Installation of a Ø2mm or Ø4mm cable gland to provide access to as many as 8 external temperature probes for calibration and validation procedures.

Ref. CG2MM & CG4MM

[Download technical data sheet](#)

ACCESSORIES



EXTERNAL TEMPERATURE PROBE ADAPTER

External adapter for continuous validation processes that provides access to an external probe (Ø3-6mm) to take temperature readings that are independent of the equipment microprocessor.

It is located on the autoclave door.

Must be installed at our factory.

Ref. EXT-TP



[Download technical data sheet](#)



TRANSPORT TROLLEY

Auxiliary trolley to aid in the loading and unloading of the autoclave.

Made of chrome iron and plastic.

The surface of each shelf is textured to prevent the load from moving.

Equipped with rubber casters to reduce noise and prevent floor wear.

Dimensions (LxDxH): 730x490x700mm

Ref. TR-TR



[Download technical data sheet](#)



PREMIUM CASTERS

Although all AES Series autoclaves include casters, this accessory offers the option of upgrading to stronger, medical grade casters that include brakes.

This enhances the mobility of the equipment.

Must be installed at our factory.

Ref. 4WHBR



CONDENSATE TANK

Water tank with a maximum capacity of 12L to capture the moisture of the condensate produced during the purging phase and to collect dirty water during cleaning operations.

Ref. TANK-AE



[Download technical data sheet](#)



TEMPERATURE DATA LOGGER

AISI-316L stainless steel disk temperature recorder with connection base and software.

Recommended for autoclave validation and for monitoring the internal temperature of containers.

Available in different sizes.

Ref. BDL-DISK3618_CL



[Download technical data sheet](#)



STERILIZATION CONTROL TAPE

Class 1 indicator for steam sterilization. The color change indicates that the materials have been processed; however, this does not guarantee adequate sterilization. Additional methods, such as biological indicators (EN ISO 11138), are required.

Pack of 5 rolls of 50m x 19mm tape.

Ref. TEST-CT



[Download technical data sheet](#)

SPECIFIC SERVICES



IQ-OQ DOCUMENTATION

Delivery of documentation and protocols for autoclave qualification through a third party.

Ref. IQ-OQ DOC



Download technical data sheet



IQ-OQ-PQ QUALIFICATION

Autoclave qualification service performed by RAYPA technicians or authorized entities. It covers the startup of the equipment and the comprehensive qualification of its performance.

Ref. IQ-OQ-PQ



Download technical data sheet



CALIBRATION CERTIFICATE FOLLOWING ENAC TRACEABILITY STANDARDS

Unitary certification of proper equipment calibration and performance in compliance with international standards.

Ref. MAPEO-ENAC



MAPPING OF STABILITY AND HOMOGENEITY

Generation of documentary evidence certifying that the temperature and pressure distribution within the autoclave is uniform and stable, in accordance with the manufacturer's design specifications.

Ref. MAP-3, MAP-7 and MAP-9



ON-SITE COMMISSIONING & TRAINING

On-site commissioning, which includes verification of the correct operation and installation of the equipment and a training session for users on the use and maintenance of the equipment.

Ref. INSAE



Download technical data sheet



REMOTE COMMISSIONING & TRAINING

Guided remote startup including a training session for users on the operation and maintenance of the equipment.

Ref. INSAE-REM



Download technical data sheet



MAINTENANCE CONTRACT

Regular inspection plan that includes technical inspection, probe calibration and compliance with the preventive maintenance plan, in addition to tariff discounts.

Ref. MANT-1.2 and MANT-1.3



EXTENDED WARRANTY

Extended warranty up to a total of 3 years.

Ref. WE-CL

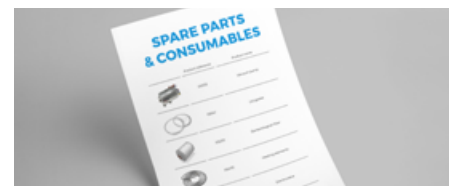

SET OF CONSUMABLES, SPARE PARTS AND ESSENTIAL COMPONENTS

Set of original spare parts, consumables and components, chosen specifically to adhere to each model's maintenance plan, intended to maximize equipment longevity and minimize downtime in the event of a malfunction.

TECHNICAL DRAWINGS OF THE AUTOCLAVE

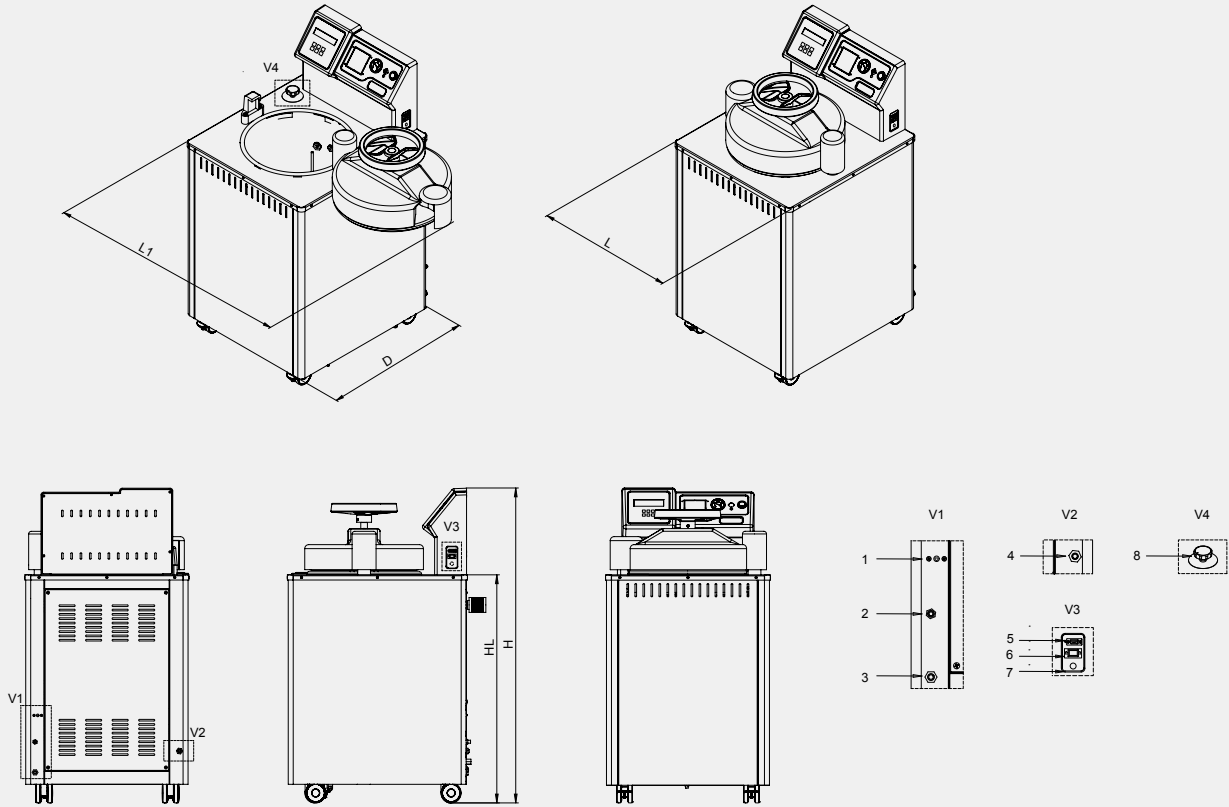

MODELS

MODELS	L LENGTH with closed door	L1 LENGTH with maximum door opening	D DEPTH	H HEIGHT	HL LOAD HEIGHT	HD DRAIN HEIGHT sterilization chamber
AES-28	505 mm	900 mm	580 mm	1110 mm	788 mm	140 mm
AES-50	505 mm	900 mm	580 mm	1290 mm	967 mm	140 mm
AES-75	610 mm	1100 mm	700 mm	1185 mm	860 mm	140 mm
AES-110	610 mm	1100 mm	700 mm	1435 mm	1112 mm	140 mm
AES-150	750 mm	1380 mm	820 mm	1400 mm	1073 mm	140 mm

CONNECTIONS

- 1 Sterilization chamber electrical heating elements safety thermostat
- 2 Safety valve outlet
- 3 Sterilization chamber drain outlet and purge outlet
- 4 Power supply cable (AES-110 and AES-150 models)
- 5 RS-232 Port
- 6 Ethernet Port
- 7 Power supply cable (AES-28, AES-50 and AES-75 models)
- 8 Two position drain tap

TECHNICAL DRAWINGS OF THE AUTOCLAVE + CLASSIC-LIFT

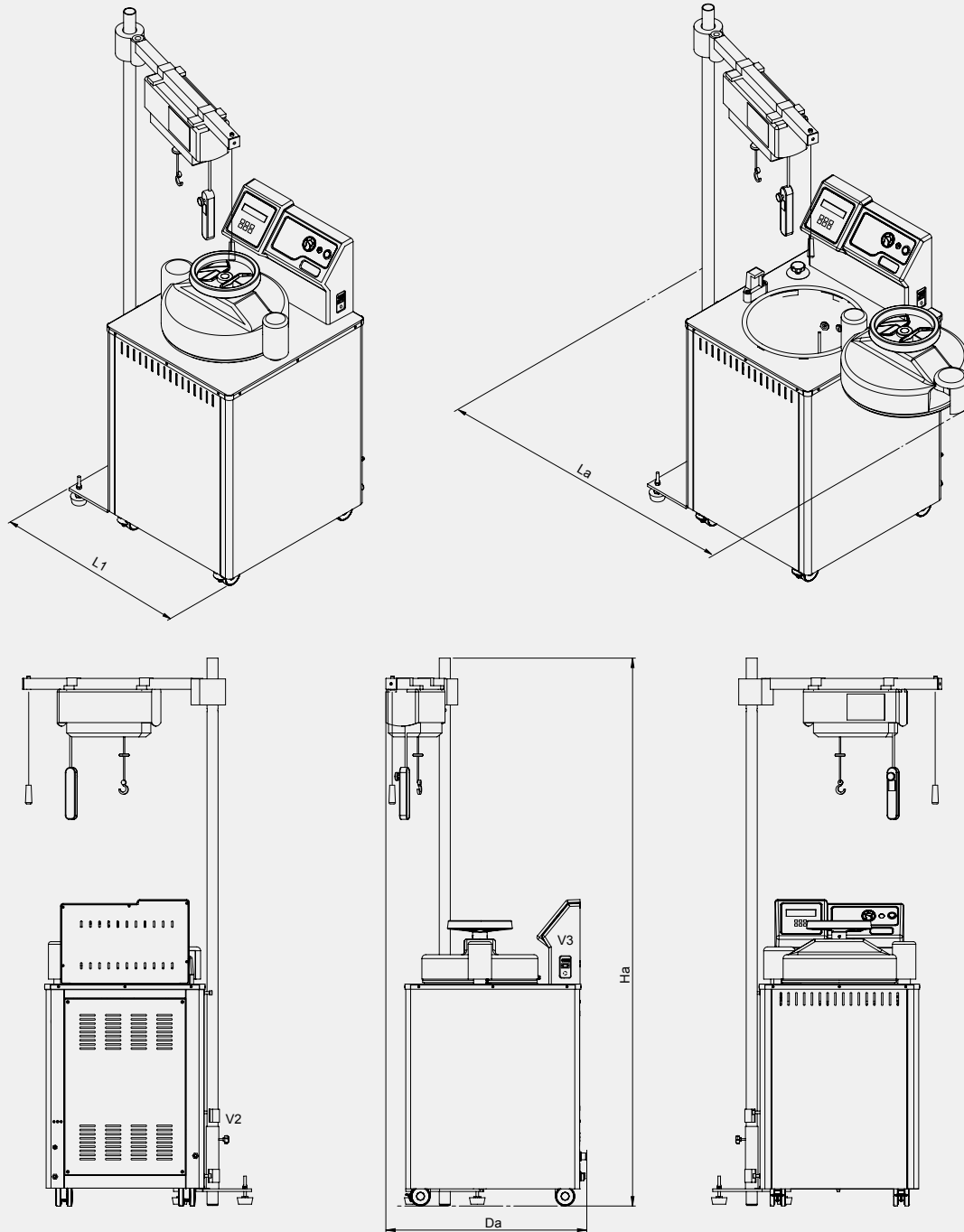

MODEL OF BASKET LIFT SYSTEM

DIMENSIONS OF BASKET LIFT SYSTEM L x D x H

AUTOCLAVE MODELS

DIMENSIONS OF BASKET LIFT SYSTEM + AUTOCLAVE La x Da x Ha

CLASSIC-LIFT

800 x 300 x 2100 mm

AES-75

1276 x 1296 x 2100 mm

AES-110

CLASSIC-LIFT-R

800 x 300 x 2600 mm











AES-110

1276 x 1296 x 2600 mm

AES-150

1543 x 1536 x 2600 mm

TECHNICAL SUMMARY

 General classification	Recommended setting	General laboratory
	Equipment placement	Floor-standing
	Load direction	Top-loading
	Chamber profile	Round
 Recommended type of load	Culture media and liquids	++
	Glassware	++
	Plastics and metal objects	++
	Laboratory waste bags	+
 Sterilization technology	Method to generate steam	Heating elements
	Type of purge	Gravity displacement
 Transfer of data	RS-232	✓
 Batch printers	Embedded printer	0
	External printer	0
 Sterilization chamber and door specifications	Sterilization chamber volume	33 - 175 L
	External building material	AISI-304
	Sterilization chamber material	AISI-316L
	Heating elements material	Incoloy® 825
	Gasket material	Silicone rubber
	Min.- max. sterilization temperature	100 - 134°C
	Maximum pressure (above atmospheric pressure)	2,1 Barg
	Mechanism to open the door	Manual wheel
	Direction in which the door opens	Lateral
	Automatic locking with pressure	✓
Thermally insulated door	✓	
 User interface and microprocessor	Screen display	Digital LCD
	Screen size	2 lines x 16 digits
	Total number of available programs	10
	Automatic microprocessor control	✓
	Timer start	✓
 Special cycles and process optimization	Agar mode (temperature holding after cycle ends 40-80°C)	✓
	Solids fast cooling (manual push-button for a faster cooling phase)	✓
	Temperature regulation by core probe	0
 Adjustable cycle parameters	Agar mode	40 - 80°C
	Temperature of sterilization phase	100 - 134°C
	Duration of sterilization phase	1 - 250 min
	Temperature regulation by core probe	On/Off
 Other specifications	Capacity of the sterilization chamber water tank	3 - 9,5 L
	Flexible temperature probe	0
	Standard casters	✓
	Premium casters with brakes	0
	Pressure gauge	✓
	Electric customization (115-230M V / 230-400T V)	0
 Services	Special models with increased heating capacity	0
	Third-party qualification (IQ-OQ-PQ)	0

++: Recommended ✓: Standard 0: Optional

TECHNICAL DATA

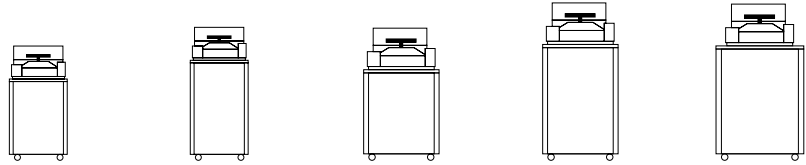

Specifications

References	AES-28	AES-50	AES-75	AES-110	AES-150
Total/usable volume of the chamber L	33/31	55/50	79/75	115/110	175/153
Usable dimensions of the chamber Ø x H mm	300 x 440	300 x 710	400 x 600	400 x 850	500 x 780
External dimensions L x D x H mm	505 x 580 x 1110	505 x 580 x 1290	610 x 700 x 1185	610 x 700 x 1435	750 x 820 x 1400
Loading height mm	795	975	870	1120	1085
Net weight Kg	61	65	98	122	198
Available heating capacities W	2000 or 3200	3200 or 5000	3200 or 6000	4500, 6000 or 9000	6000 or 9000
Standard voltage* V	230	230	230	400	400
Frequency Hz	50/60	50/60	50/60	50/60	50/60

*Other voltages and electrical configurations available on request. Special models with increased heating capacity may operate with other voltages.

Safety features

- Safety valve.
- Safety thermostats with manual rearm for the heating jacket and the heating elements.
- Pneumatic door blocking system while positive pressure exists inside the sterilization chamber.
- Open door sensor.
- Thermally insulated door.
- Heating elements cover.
- Several visual and acoustic safety and warning alarms.

Regulations

All our AES Series autoclaves are designed to comply with the strictest international directives and standards, including the following regulations:

- **EN-61010-1** Safety requirements for electrical equipment for measurement, control and laboratory use. **Part 1:** General requirements.
- **EN-61010-2-040 Part 2-040:** Requirements for laboratory autoclaves.
- **EN-61326** Electrical equipment for measurement, control and laboratory use. EMC requirements.
- **AD 2000 Merkblatt** Pressure vessels.
- **2014/35/UE** Low voltage.
- **2014/30/UE** Electromagnetic compatibility.
- **2014/68/UE** Pressure equipment.

General features

Adjustable sterilization temperature	100 - 134 °C
Adjustable sterilization time	1 - 250 min
Max. pressure	2,1 Barg
Sterilization control system	Fully automatic microprocessor control by either chamber temperature probe or flexible temperature probe
Air purge system	Gravity displacement
External building material	AISI-304 stainless steel
Sterilization chamber material	AISI-316L stainless steel
Heating elements material	Incoloy® 825
Gasket material	Silicone rubber
Connection to PC	RS-232
Connection to printer	RS-232 or embedded
Number of programs	10 (4 preset and 6 user free)
Programmable auto-start	Up to 24 h
Screen type	LCD display
Opening door mode	Horizontal swiveling door with blocking wheel
Monitoring of sterilization parameters	Self-control of obtained values (T° & t) vs programmed values. Cycle is automatically interrupted if obtained values differ from programmed values
Pressure display	Pressure gauge on control panel
Water management	Water is directly poured into the sterilization chamber
Drainage system	Drainage connection operated by an independent drainage valve on control panel for manual release of sterilization chamber water tank
Casters	Included standard casters. Optional upgrade to medical grade casters with brakes



Алматы (727)345-47-04
Ангарск (3955)60-70-56
Архангельск (8182)63-90-72
Астрахань (8512)99-46-04
Барнаул (3852)73-04-60
Белгород (4722)40-23-64
Благовещенск (4162)22-76-07
Брянск (4832)59-03-52
Владивосток (423)249-28-31
Владикавказ (8672)28-90-48
Владимир (4922)49-43-18
Волгоград (844)278-03-48
Вологда (8172)26-41-59
Воронеж (473)204-51-73
Екатеринбург (343)384-55-89

Иваново (4932)77-34-06
Ижевск (3412)26-03-58
Иркутск (395)279-98-46
Казань (843)206-01-48
Калининград (4012)72-03-81
Калуга (4842)92-23-67
Кемерово (3842)65-04-62
Киров (8332)68-02-04
Коломна (4966)23-41-49
Кострома (4942)77-07-48
Краснодар (861)203-40-90
Красноярск (391)204-63-61
Курск (4712)77-13-04
Курган (3522)50-90-47
Липецк (4742)52-20-81

Магнитогорск (3519)55-03-13
Москва (495)268-04-70
Мурманск (8152)59-64-93
Набережные Челны (8552)20-53-41
Нижний Новгород (831)429-08-12
Новокузнецк (3843)20-46-81
Ноябрьск (3496)41-32-12
Новосибирск (383)227-86-73
Омск (3812)21-46-40
Орел (4862)44-53-42
Оренбург (3532)37-68-04
Пенза (8412)22-31-16
Петрозаводск (8142)55-98-37
Псков (8112)59-10-37
Пермь (342)205-81-47

Ростов-на-Дону (863)308-18-15
Рязань (4912)46-61-64
Самара (846)206-03-16
Санкт-Петербург (812)309-46-40
Саранск (8342)22-96-24
Саратов (845)249-38-78
Севастополь (8692)22-31-93
Симферополь (3652)67-13-56
Смоленск (4812)29-41-54
Сочи (862)225-72-31
Ставрополь (8652)20-65-13
Сургут (3462)77-98-35
Сыктывкар (8212)25-95-17
Тамбов (4752)50-40-97
Тверь (4822)63-31-35

Тольятти (8482)63-91-07
Томск (3822)98-41-53
Тула (4872)33-79-87
Тюмень (3452)66-21-18
Улан-Удэ (3012)59-97-51
Ульяновск (8422)24-23-59
Уфа (347)229-48-12
Хабаровск (4212)92-98-04
Чебоксары (8352)28-53-07
Челябинск (351)202-03-61
Череповец (8202)49-02-64
Чита (3022)38-34-83
Якутск (4112)23-90-97
Ярославль (4852)69-52-93

Россия +7(495)268-04-70

Казахстан +7(727)345-47-04

Беларусь +(375)257-127-884

Узбекистан +998(71)205-18-59

Киргизия +996(312)96-26-47

<https://raypa.nt-rt.ru> || rpa@nt-rt.ru